

Specifications

Hold off voltage: 10-15 Vdc (13.6 Vdc nominal)
 Current Consumption @ 13.6 Vdc:

	Quiescent	Sounder	Strobe	Total
Cegura @ 85dB (A)	SAB ≤ 40 mA	~20mA	~190mA	~160mA
Cegura @ 115dB (A)	SAB ≤ 40 mA	~250mA	~190mA	~360mA

Sounder Type:

Acoustic Output: Piezo
Tone

Sound duration: ≤ 15 minutes; ≤ 3 minutes or intermittent

Sound Output Levels: ~85dB(A) @ 3 metre / ~115dB(A) @ 1 metre

Triggering Method: -ve applied, +ve applied or hold off removed

Strobe Type:

Flash Rate: Xenon
~ 60 per minute

Strobe saver mode: ~ 7 per minute

Triggering Method: -ve applied, +ve applied or hold off removed

Rechargeable Battery Type:

NIMH
7.2 volt

Nominal Voltage: 330mAh

Capacity:

LED Indicators:

Tamper and hold off

Tamper:

Removal from mounting, cover and screw.

Dimension including outer cover:

305mm x 180mm x 60mm

EN50131-1: 2006 + A1: 2009

Grade 3 Environmental Class IV

EN50131-4: 200

Warning device Type: Z

Safety Precautions

- Never remove the cover when the strobe is flashing.
- Wait 3 minutes after the strobe has stopped flashing before removing the cover.
- The piezo transformer will be hot during and after sounding. Whilst not directly hazardous, touching it when hot will cause discomfort and should be avoided.
- When the Cegura is in alarm condition, high voltages are present. Before removing the cover, stop the piezo and strobe from operating.
- Failure to observe the following precautions regarding the re-chargable battery could lead to danger of heating, ignition, explosion and leaking of hazardous chemicals.**
- Do not throw into a fire.
- Do not heat.
- Do not overcharge.
- Do not reverse charge.
- Do not short circuit the battery wires.
- Do not disassemble.
- Always observe local regulations when disposing of a battery.
- Plastic bags can suffocate, always dispose of packaging carefully.



RoHS compliant.

12

BCCEQSUPBK/*
BCCEQ/COV/*

* Denotes Colour

Cegura

External Warning Device.

Modern design with ultra low profile.

Dual 85dB(A) and 115dB(A) sound output.

Back lighting strobe.

Selectable trigger wire monitoring.

Selectable timers.

Negative or Positive trigger option.

Fault Output

Test Input

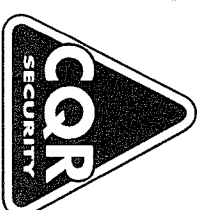

Operating and Installation Instructions

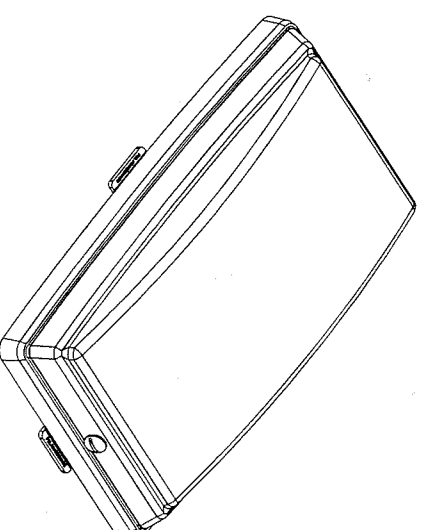

Description

This self powered external warning device can be installed in security systems up to and including Grade 3 Environmental class IV in accordance with EN50131-1: 2006 + A1: 2009. It complies to EN50131-4: 2009, WD type Z. The warning device features one piezo and a back lighting strobe for audible and visual indication of an alarm activation. Installer features include selectable timing options and selectable sound output of 85dB(A) and 115dB(A) measured at 3 metres and 1 metre respectively.

CQR Security, 125, Pasture Road, Moreton, Wirral, CH46 4TH, United Kingdom

Tel: +44 (0) 151 606 9595 Support: +44 (0) 151 606 6311 email: info@cqr.co.uk Web http://www.cqr.co.uk

BCCED Issue 2.0

1

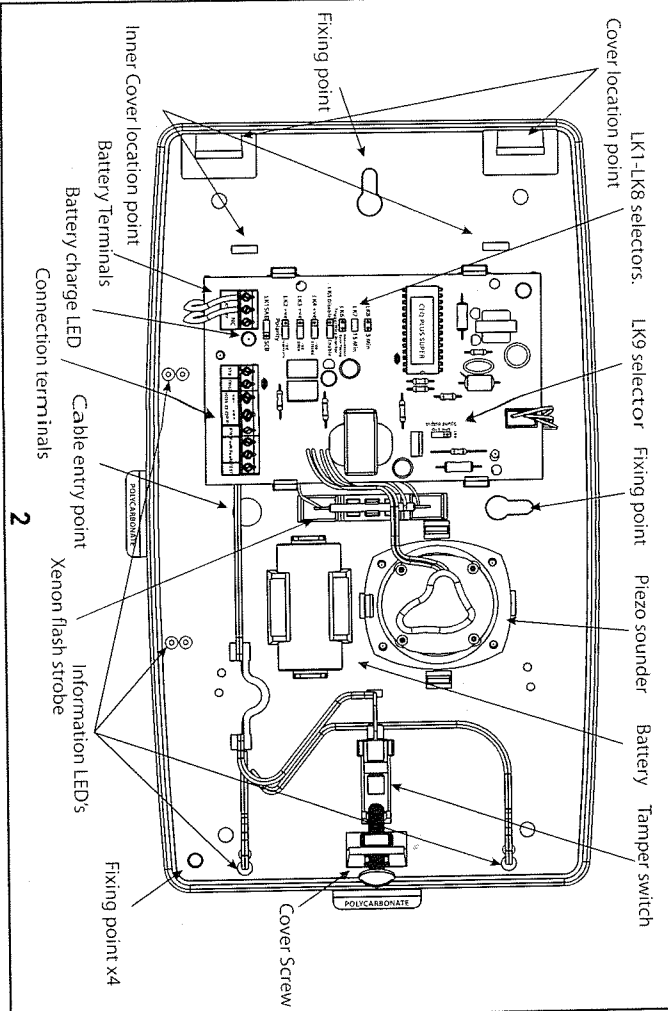
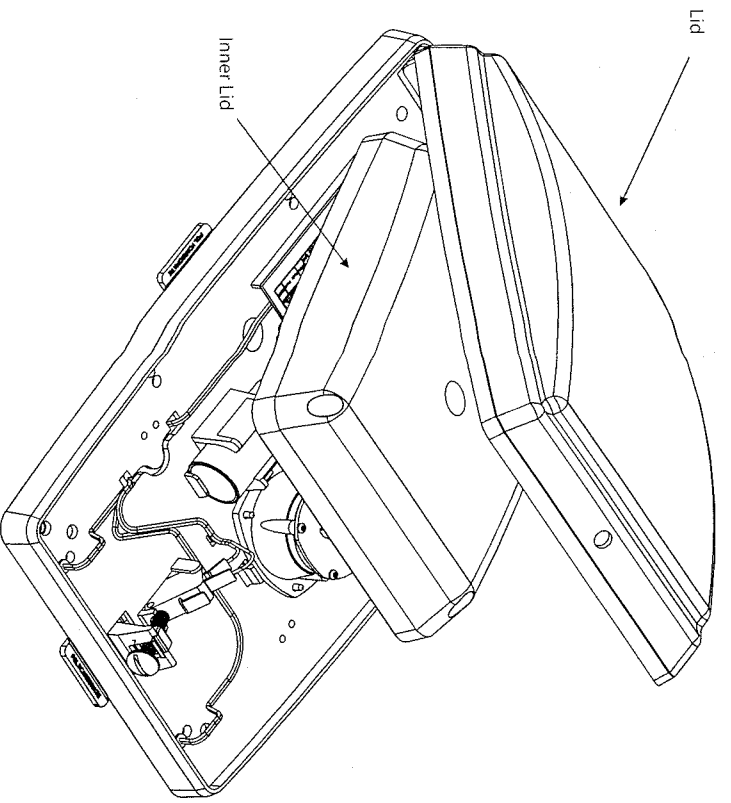

Ceaura Reference Chart

Manufacturer	Model	STB	Trig	Hold Off -	Hold Off +	RTN
ADE	Panels	STROBE-	B	A	D	T
Ademco	Infra 16	STR-	BELL-	0V	12V	BELL TAMP R
Artech	Panels	STROBE-	EXT BELL	BHO	BELL +	EOL res TR
Castle	2500/1000/15-1700 2700 Omega ZX1250	STR- STR- STR-	BELL - NO / C B - EXB-	HO - HO - 12V- HOLD OFF-	HO + HO + HOLD OFF+	SAB TAMP SAB TAMP ST + return ST + return
C & K	800L 700L 703 Active 5	ST- ST- ST- ST-	S- S- NO / COM S-	V - BELL - 0V V -	V + BELL + SOUND + AUX	R - R - R - 2A TAMP
DSC	Panel 832	STRB TRIG PG2	BELL TRIG BELL -	HOLD OFF -VE AU -	HOLD OFF +VE BELL +	Zone of TAMP Z1
Galaxy	8 60 16	R101/NO SUN	R101/1 BELL	HOLD - AUX - HOLD -	HOLD + AUX + HOLD +	T T T
Gardtech	350 370 580/800	- STB STROBE- STROBE-	BELL - BELL - BELL -	SCBA BELL HOLD - BELL HOLD -	BELL + BELL + BELL +	SCBP SAB TAMP SAB TAMP
Mannier	400/790/900/2200 TSD402/TS690/TS700 800	STB STB - STRB	TRG - TRG - BELL O/P	0V HO - H/O -	BELL + HO + H/O +	BELL TAMP TR - BELL TAMP
Pyronix	Conquero/ Paragon E Paragon Plus/Octogon Sterling 10 NEW Sterling 10	STB STB STB	BA BA BA	B/S - B - B -	B/S + B + B +	BT BT BT
Scantronic	9448/9800 8136 4600/4500 9100/9105 9851 500R	STR OP2 STR NO NO NO STR	BELL OP1 BELL NO NO NO BELL	0V AUX - VE 0V COM 0V 0V 0V	12V + AUX + VE AUX + 12V 12V 12V	TR A/T TR TR TR TR
Texecon	R8	S	B	D	A	C

Whilst every effort has been made to ensure that the contents of this booklet are correct CQR does not accept liability for loss or damage caused or alleged to have been caused directly or indirectly by this booklet. CQR Security reserve the right to change the design/ specification of this product and/ or the contents of this booklet without notice.

Cegura Diagnostics

SYMPTOM	CAUSE	REMEDY
Hold-off and tamper LED's flash alternately once per second	Normal operation	N/A
Tamper LED flashes twice per second	Rechargeable battery connected and the tamper switch is closed. No hold-off voltage present	Apply hold-off voltage
Red battery charging LED is not illuminated	Rechargeable battery faulty, damaged or low charge	Allow the battery to recharge. Check condition of battery and replace if necessary
Tamper LED not illuminated	Tamper switch open	Close tamper switch
Hold-off LED not illuminated	12Vdc not present at hold-off terminals	Connect 12Vdc to hold-off terminals, check fuses in panel

Cegura Mounting Instructions

Identify a suitable mounting location for the warning device on a flat wall. It should not be possible to reach the device without the aid of access equipment, were practical it should be sited under the eaves to give additional protection. To remove the lid, unscrew the retaining screw and carefully remove the lid. Mark the fixing points on the surface of the selected location. Drill 3 x 8mm holes x 41 mm deep for the enclosed wall plugs, insert the wall plugs into the holes, feed the cable through the cable entry point on the sounder and using the enclosed screws, fix the sounder to the selected location.

Please note in order for the tamper protection to conform to grades requiring removal from mounting protection, a fourth screw is needed under the tamper switch arm as shown below.

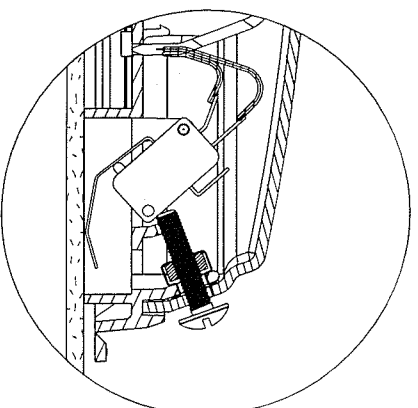

Normal Installation

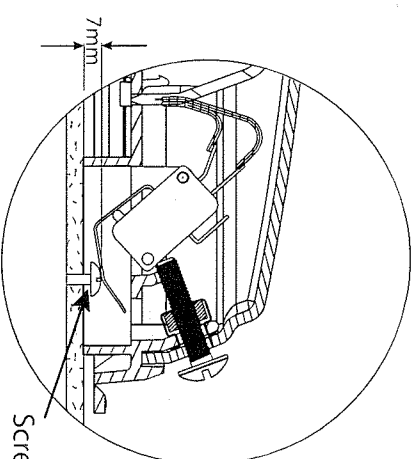

Removal from mounting installation.

Once the backplate has been mounted, the tamper mechanism should be checked for correct operation by fitting the lid and if necessary bend the tamper arm to suit. Once this is complete, the wiring should be carried out in accordance with the next few pages.

Cequira Circuit Board Layout

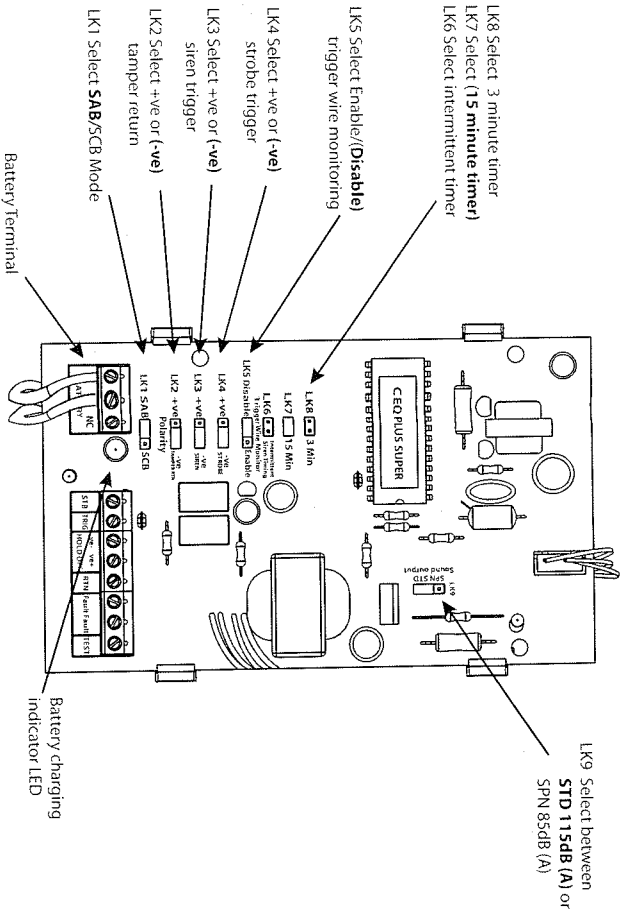

Terminal Descriptions

Terminal /Link	Description
STB	Signal from control panel to activate strobe
TRIG	Signal from control panel to activate siren
HOLD OFF -	Permanent 0v supply from the control panel -ve
HOLD OFF +	Permanent 12vdc supply from the control panel +ve
RTN	Tamper return to the control panel
FAULT	Closed circuit going open during a fault condition
TEST	+ve signal from the control panel to activate self test routine
LK1	Select SAB/SCB
LK2	Select tamper return signal +ve or -ve
LK3	Select siren trigger +ve or -ve
LK4	Select strobe trigger +ve or -ve
LK5	Select trigger wire monitoring Enable or Disable . See Important Note
LK6	Intermittent timer
LK7	15 minute timer
LK8	3 minute timer
LK9	Selectable Sound Level: STD = 115dB (A) SPN = 85dB (A) . See Important Note

Note: Default settings are in **bold**.

Important Note: To comply with Grade 3 requirements, trigger wire monitoring must be enabled, and the sound level must be set to STD unless national or local variations require a lower dB(A) level.

Quick Set-up Guide

Installing two Cequira units on one system with or without trigger wire monitoring.

1. If trigger wire monitoring is required, ensure that the trigger wire monitoring jumper is in the enabled position and that two 1k resistors are fitted in the panel where indicated below, if they are required.
2. Connect the five wires between Cequira "1" and "2" as shown. Ensure the wire from the Hold Off- terminal on Cequira "1" is connected to a terminal block set in Cequira "1" for connection to the control panel.
3. Connect the batteries, fit the covers to the Cequira's and then power up the control panel.

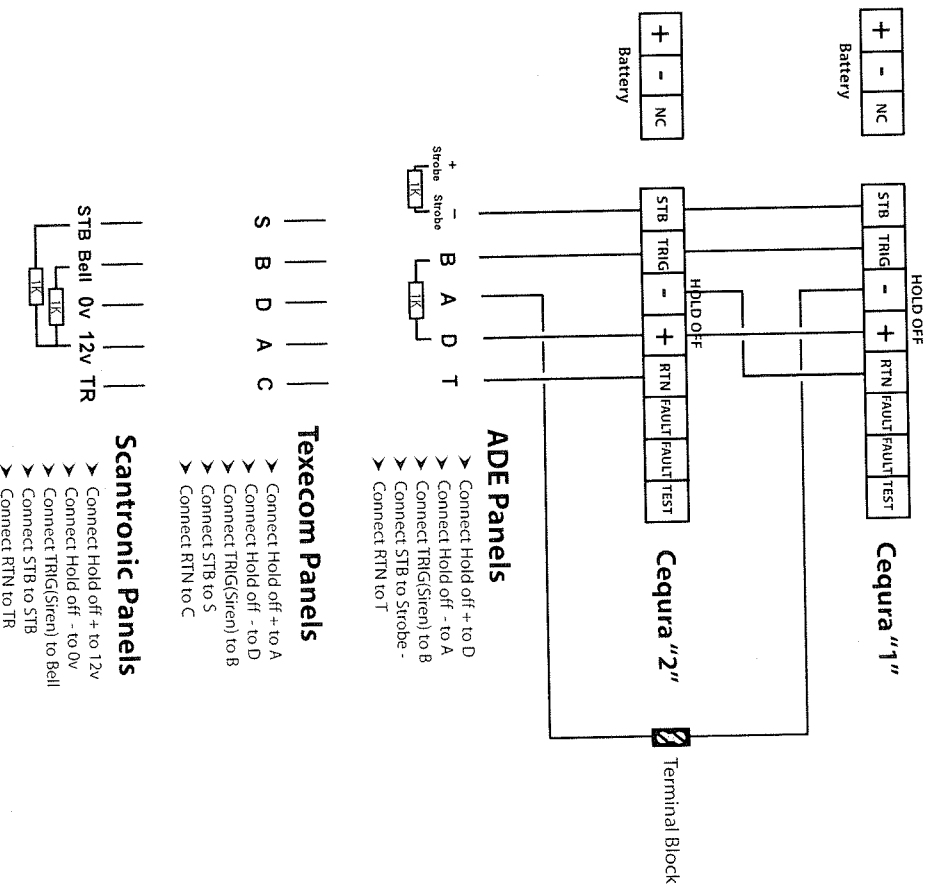

ADE Panels

- > Connect Hold off + to D
- > Connect Hold off - to A
- > Connect TRIG(Siren) to B
- > Connect STB to Strobe -
- > Connect RTN to T

Texecom Panels

- > Connect Hold off + to A
- > Connect Hold off - to D
- > Connect TRIG(Siren) to B
- > Connect STB to S
- > Connect RTN to C

Scantronic Panels

- > Connect Hold off + to 12v
- > Connect Hold off - to 0v
- > Connect TRIG(Siren) to Bell
- > Connect STB to STB
- > Connect RTN to TR

> Check that the green LED's are flashing alternately.

> Use the control panel to check the functions of the Cequira.

> After approx 5mins the test mode will expire and the LED's will speed up.

Quick Set-up guide.

* With trigger wire monitoring.

1. Ensure that the trigger wire monitoring jumper is in the enabled position.
2. Connect the wires to the Cequra as shown below.
3. Plug in the battery and one beep will be heard.
4. Ensure the tamper switch will close properly and fit the lid, two beeps will be heard.
5. The tamper LED should start to flash twice a second. This will stay like this until hold off voltage is applied or the battery goes flat.
6. Connect the control panel as indicated below and switch on. Two 1 k resistors must be fitted prior to power up.
7. The hold off LED will now flash with the tamper LED. Two beeps will be heard.
8. After a few seconds the unit will beep again and the LED's will flash alternately.
9. After 5 minutes the engineer mode will expire and the LED's will flash at the normal rate of once per second.

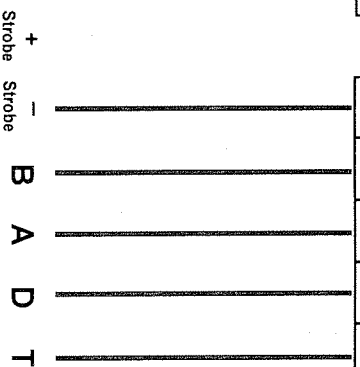
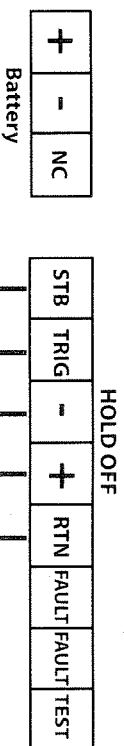

ADE Panels

- > Connect Hold off + to D
- > Connect Hold off - to A
- > Connect TRIG(Siren) to B
- > Connect STB to Strobe -
- > Connect RTN to T

Texecom Panels

- > Connect Hold off + to A
- > Connect Hold off - to D
- > Connect TRIG(Siren) to B
- > Connect STB to S
- > Connect RTN to C

Scantronic Panels

- > Connect Hold off + to 12v
- > Connect Hold off - to 0v
- > Connect TRIG(Siren) to Bell
- > Connect STB to STB
- > Connect RTN to TR

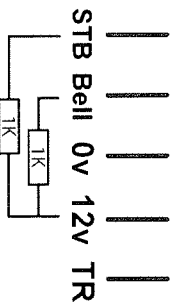

*Special note

In the event of failure or damage to the trigger wires of the siren or strobe, the Cequra will indicate by sounder or strobe depending on which one has failed.

Features

Engineer Hold-Off

During the initial connection, it is possible to connect the rechargeable battery without the siren activating; thus, the siren can be mounted and connected at the same time (one trip up the ladder) without the need to return to the unit once the hold-off voltage is applied. *Please note this feature is only applicable upon initial installation or if the Cequra has been completely de-powered i.e. Hold-off supply and the rechargeable battery disconnected.*

Engineer Mode

When hold-off voltage has been applied, the unit will first self check, before entering test mode. This test mode lasts for 5 minutes. During this time, if the sounder is tested, it will sound for 3 or 15 seconds only, depending on which time is selected. This allows testing of the installation without excessive noise. When the test mode expires the unit will emit a brief sound and the flashing LED's will speed up to 1 flash per second.

Strobe Tube Saver

When activated, the strobe will flash at 60 flashes per minute for the first hour, after which the flash rate reduces to 1 every 8 seconds.

Battery Monitor

The rechargeable battery is constantly monitored to determine whether it is no longer able to power the device in the event of the hold off voltage being removed. Upon installation the battery monitor may indicate a fault for a few minutes until the battery has received sufficient charge.

Fault Output

This output signals a failure of the battery. When a failure is detected the normally closed circuit goes open. When a remote test is started, the fault output opens the circuit which remains open if a fault is detected and closes if no faults are detected. This output also opens circuits when the device detects that the siren trigger wire has been removed. (Only if trigger wire monitoring is enabled)

Test Input

Applying a positive signal from a control panel to this connection will start a local self test procedure.

Options

LK1 SAB/SCB

SAB (Default): - When activated, all power required to operate the siren is drawn from the control panel

SCB: - When activated, all the power to operate the siren is drawn from the device' s internal battery.

LK2 Tamper RTN

Allows you to select either a negative signal (default) or a positive signal for the tamper return output.

LK3 Siren

Allows you to select the triggering method to activate the siren, either -ve applied (default) or +ve applied.

LK4 Strobe

Allows you to select the triggering method to activate the strobe, either -ve applied (default) or +ve applied.

Options (continued)

LK5 Trigger Wire Monitoring

This is mandatory for all grade 3 installations. When selected, the device monitors the siren and strobe trigger wire's integrity by means of monitoring resistors. These resistors are connected to the opposite signal that is required to activate the siren or strobe i.e. negative siren trigger signal (default), the monitoring resistor is connected between a positive and the trigger wire in the control panel. In the event of the siren trigger wire being cut or removed, the fault output circuit will open, in the event of the strobe trigger wire being cut or removed the strobe will start to flash. The fault output circuit will NOT be activated.

Note: Fitting the resistor in the device does not comply with grade 3 requirements.

LK6 Intermittent Timer

When selected the siren will sound for a maximum cycle of 3 times.

50 sec ON, 50 sec OFF, 50 sec ON, 50 sec OFF, 50 sec ON then stops. (times are approximate).

LK7 15 Min Timer (default)

When selected the siren will sound for a maximum of 15 minutes (times are approximate).

LK8 3 Min Timer

When selected the siren will sound for a maximum of 3 minutes (times are approximate)

LK9 Sound Output

Allows selection of the sound output level of either 115dB (A) @1 m (default) or 85 dB (A) @3m

Operating Instructions

Please follow the Set-up guide for instructions on setting up the device for the configuration required.

- To activate the siren apply an appropriate signal (depending on selected option **LK3**) to the **TRIG** terminal. To deactivate the siren, remove the applied signal.

- To activate the strobe apply an appropriate signal (depending on selected option **LK4**) to the **STB** terminal. To deactivate the strobe, remove the applied signal.

- If the devices tamper protection is activated, the **RTN** terminal signal (depending on selected option **LK2**) will be removed. Deactivating the tamper protection will result in the terminal being restored.

- If the rechargeable battery is disconnected from the device or is not capable of supplying power to the device, then, in the event of the removal of the remote power source, the **Fault** output circuit will open.

- The loss of the remote power source to the device will activate the siren for the time selected by **LK6, LK7 or LK8**

Quick Set-up guide.

* Without trigger wire monitoring.

1. Ensure that the trigger wire monitoring jumper is in the disabled position.
2. Connect the wires to the Cequra as shown below.
3. Plug in the battery and one bleep will be heard.
4. Ensure the tamper switch will close properly and fit the lid, two bleeps will be heard.
5. The tamper LED should start to flash twice a second. This will stay like this until hold off voltage is applied or the battery goes flat.
6. Connect the control panel as indicated below and switch on.
7. The hold off LED will now flash with the tamper LED. Two bleeps will be heard.
8. After a few seconds the unit will bleep again and the LED's will flash alternately.
9. After 5 minutes the engineer mode will expire and the LED's will flash at the normal rate of once per second.

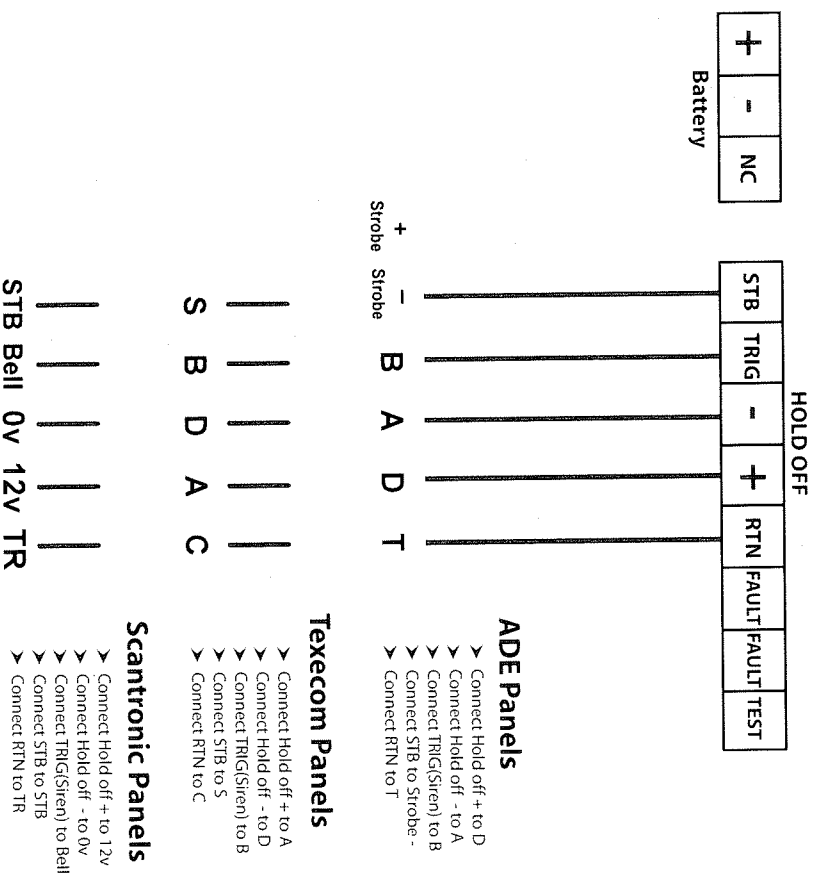

*Special note

Please be aware that if trigger wire monitoring is disabled, in the event of failure or damage to the trigger wires of the siren or strobe, in most cases the control panel will not signal the fact that the siren and/or strobe are in fact disabled.